

51.2V314Ah HOME STORAGE BATTERY PACK

PRODUCT MANUAL

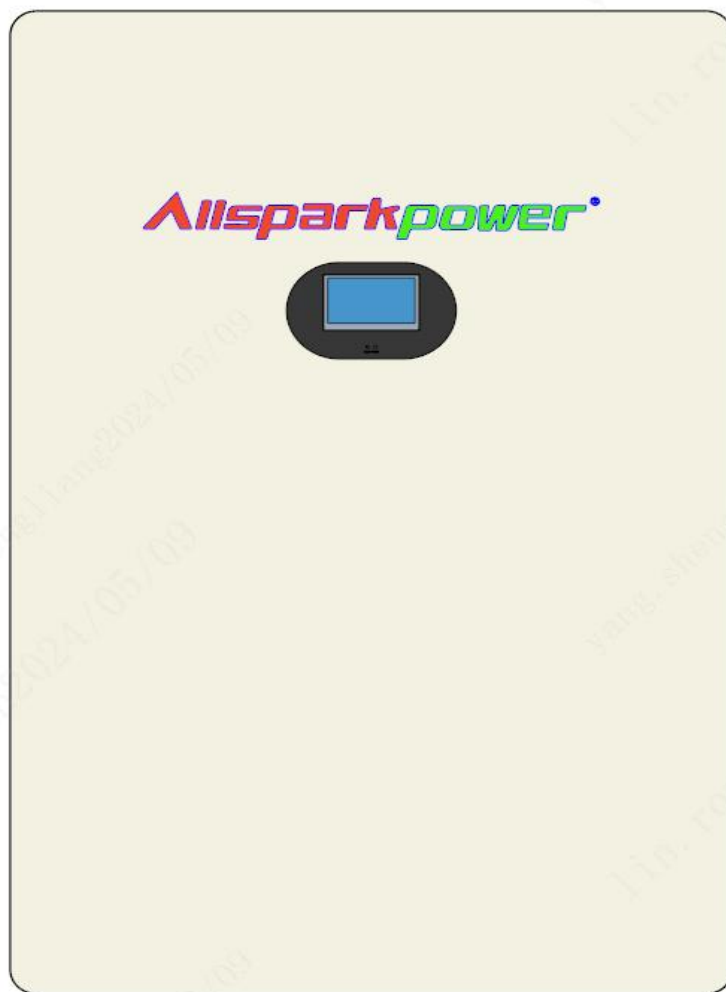

Prepared by	Checked by
RongChun Lin	Dingan Tao
2024-05-06	2024-05-06

Product Modification Record List

Revision	Date	Mark	Modified content	Approved by
A/0	2024-05-06	/	NEW RELEASE	/

This manual introduces 51.2V314Ah from Allsparkpower Storage. Please read this manual before you to install the battery pack and follow the instruction carefully during the installation process. Any confusion, please contact Allsparkpower immediately for advice and clarification.

Table of Contents

1. Safety Precautions	3
1.1 Before Connecting	3
1.2 In Using	4
2. Introduction	5
2.1 features:	6
2.2 Product dimensions and parameters	6
2.3 Equipment Interface Instruction	7
2.4 BMS basic parameters and characteristics	8
3. Safe handling of lithium batteries Guide	12
3.1 Schematic Diagram of Solution	12
3.2 Explanation of Symbol	12
3.3 Tools	13
3.4 Safety Gear	13
4. Installation	14
5. Trouble Shooting Steps	17
5.1 Problem determination based on:	17
5.2 Preliminary determination steps:	17
5.3 The battery cannot be charged or discharged	17
6. Emergency Situations	18
6.1 Leaking Batteries	18
6.2 Fire	18
6.3 Wet Batteries	18
6.4 Damaged Batteries	18

1. Safety Precautions



Reminding

- 1) It is very important and necessary to read the user manual carefully (in the accessories) before installing or using battery. Failure to do so or to follow any of the instructions or warnings in this document can result in electrical shock, serious injury, or death, or can damage battery, potentially rendering it inoperable.
- 2) If the battery is stored for long time, it is required to charge them every six months, and the SOC should be no less than 90%;
- 3) Battery needs to be recharged within 12 hours, after fully discharged;
- 4) Do not expose cable outside;
- 5) All the battery terminals must be disconnected for maintenance;
- 6) Please contact the supplier within 24 hours if there is something abnormal.
- 7) Do not use cleaning solvents to clean battery;
- 8) Do not expose battery to flammable or harsh chemicals or vapors;
- 9) Do not paint any part of battery, include any internal or external components;
- 10) Do not connect battery with PV solar wiring directly;
- 11) The warranty claims are excluded for direct or indirect damage due to items above.
- 12) Any foreign object is prohibited to insert into any part of battery.



Li-ion



Warning

1.1 Before Connecting

- 1) After unpacking, please check product and packing list first, if product is damaged or lack of parts, please contact with the local retailer;
- 2) Before installation, be sure to cut off the grid power and make sure the battery is in the turned-off mode;

- 3) Wiring must be correct, do not mistake the positive and negative cables, and ensure no short circuit with the external device;
- 4) It is prohibited to connect the battery and AC power directly;
- 5) The embedded BMS in the battery is designed for 51.2VDC, please DO NOT connect battery in series;
- 6) Battery system must be well grounded and the resistance must be less than 4Ω ;
- 7) Please ensured the electrical parameters of battery system are compatible to related equipment;
- 8) Keep the battery away from water and fire.

1.2 In Using

- 1) If the battery system needs to be moved or repaired, the power must be cut off and the battery is completely shut down;
- 2) It is prohibited to connect the battery with different type of battery.
- 3) It is prohibited to put the batteries working with faulty or incompatible inverter;
- 4) It is prohibited to disassemble the battery (QC tab removed or damaged);
- 5) In case of fire, only dry powder fire extinguisher can be used, liquid fire extinguishers are prohibited;
- 6) Please do not open, repair or disassemble the battery except staffs from Allsparkpower or authorized by Allsparkpower. We do not undertake any consequences or related responsibility which because of violation of safety operation or violating of design, production and equipment safety standards.

2. Introduction

With the widespread use of iron-lithium batteries in the household energy storage industry, high performance, high reliability, and high cost performance are required for battery pack. This product is a battery pack specifically designed for household energy storage and can be widely used in household energy storage, Industrial and commercial energy storage. 51.2V314Ah has built-in BMS battery management system, which can manage and monitor cells information including voltage, current and temperature. What's more, BMS can balance cells charging and discharging to extend cycle life.

Multiple battery packs can connected in parallel to expand capacity and power in parallel for larger capacity and longer power supporting duration requirements.

2.1 Normal performance:

The whole module is non-toxic, non-polluting and environmentally friendly;

Cathode material is made from LiFePO₄ with safety performance and long cycle life;

Battery management system (BMS) has protection functions including over-discharge, over-charge, over-current, high/low temperature and cell balancing;

The battery pack can automatically manage charge and discharge state and balance current and voltage of each cell;

Flexible configuration, multiple battery modules can be in parallel for expanding capacity and power

Adopted self-cooling mode rapidly reduced system entire noise;

The module has less self-discharge, up to 6 months without charging it on shelf, no memory effect, excellent performance of shallow charge and discharge;

Working temperature range is from -10°C to 50°C, (Charging 0~50°C; discharging -10~50°C) with excellent discharge performance and cycle life;

2.2 Product dimensions and parameters

parameter:

	Item	parameters	Note
Battery pack	Combination method	16S1P	LiFePO4
	Nominal Capacity	314Ah	0.2C,@25°C
	Minimum Capacity	314Ah	0.2C,@25°C
	Nominal Voltage	51.2V	
	Energy	16076Wh	
	Charge Voltage	58.4V	
	Discharge cut-off voltage	43.2V	Discharge Cut-off Voltage
	Charge Method	CC/CV	58.4V
	Standard Charge Current	150A	
	Max. Charge Current	200A	
	Standard Discharge Current	150A	
	Max. Continues Discharge current	200A	
	Cycled Capacity	4000 times	80%
	Internal Impedance	≤30mΩ	Internal resistance measured at AC 1KHz after 50% charge
	Dimension	D:188.21mm W:800mm H:1200mm	
	Communication	RS485/RS232/CAN	
Weight	Approx.150kg		

Product size:



D: 188.2mm W: 800mm H:1200mm

2.3 Equipment Interface Instruction

51.2V314Ah Product Interface

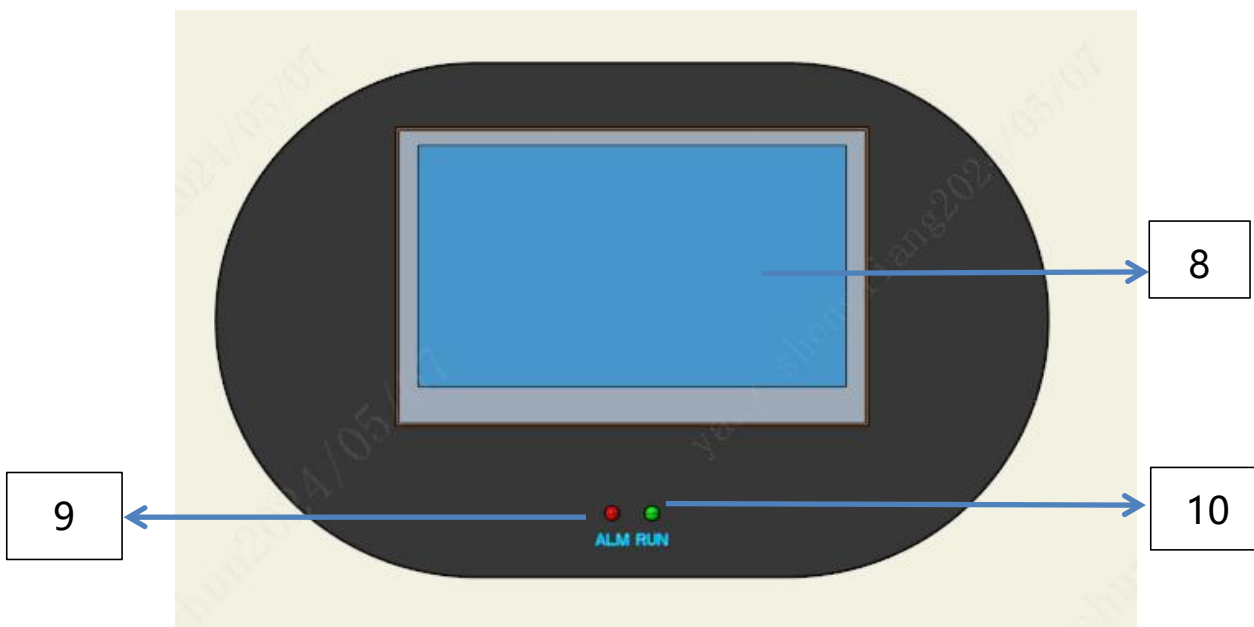
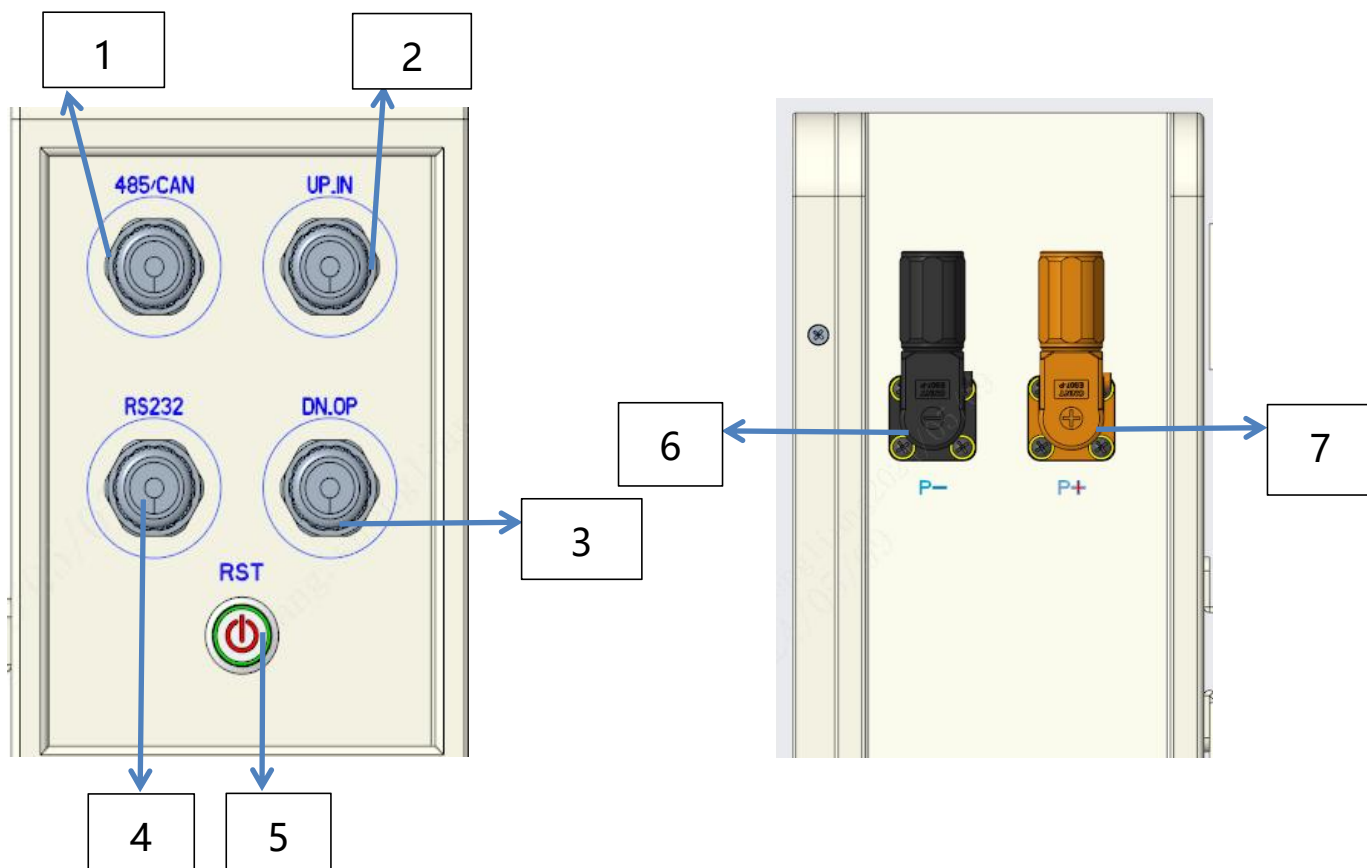

NO.	Description	Function description
1	RS485/CAN	Communication port with PCS

2	UP_IN	Automatic address input signal for cascade communication
3	DN_OP	Automatic address output signal for cascade communication
4	RS232	RS232 communication interface (for battery condition monitoring)
5	RST	On/OFF button
6	P-	Battery-
7	P+	Battery+
8	LCD	Display battery status information
9	ALM	Alarm and protection indicator lights
10	RUN	Running indicator light

2.4 BMS basic parameters and characteristics



BMS Parameters:

NO.	Item		Factory default parameter	Could you set	Remark
1	Cell Over-charge Protection	Cell Over-charge Voltage Alarm	3600mV	Can be set	
		Cell Over-charge Voltage Protection	3650mV	Can be set	
		Cell Over-charge Protection Delay Time	1.0S	Can be set	
	Cell Over voltage Protection Release	Cell Over-charge Protection Release voltage	3380mV	Can be set	
		Capacity Release	SOC < 96%	Can be set	
		Release Once Discharge	Discharge Current > 1A		
2	Cell Over discharge Protection	Cell Over-discharge Voltage Alarm	2800mV	Can be set	After 30 seconds of over discharge protection, it will enter low-power mode if it still cannot Recover
		Cell Over-discharge Voltage Protection	2700mV	Can be set	
		Cell Over-discharge Protection Delay Time	1.0S	Can be set	
	Cell Over-discharge Protection Release	Cell Over-discharge Protection Release Voltage	2950mV	Can be set	
		Release when Charging	Charger Connection is detected		
3	Pack Over charge Protection	Pack Over-charge Voltage Alarm	57.6V	Can be set	
		Pack Over-charge Voltage Protection	58.4V	Can be set	
		Pack Over-charge Protection Delay Time	1.0S	Can be set	
	Overall Over Voltage Protection Release	Pack Over-charge Protection Release Voltage	54V	Can be set	
		Capacity Release	SOC < 96%	Can be set	
		Release Once Discharge	Discharge Current > 2A		
4	Pack Over-discharge Protection	Pack Over-discharge Voltage Alarm	44.8V	Can be set	Over discharge protection after 30 seconds, still can not recover, will enter the low power mode
		Pack Over-discharge Voltage Protection	43.2V	Can be set	
		Pack Over-discharge Protection Delay Time	1.0S	Can be set	
	Pack Over-discharge Protection Release	Pack Overdischarge Protection Release Voltage	47.2V	Can be set	
		Release Once Charge	Charger Connection is detected		
5	Over-current Charge Protection	Over-current Charge Alarm	205A	Can be set	After 10 times, the state will be locked and no longer automatical ly release
		Over-current Charge Protection	210A	Can be set	
		Over-current Protection Delay Time	1.0S	Can be set	
	Over-current Charge Protection	Auto Release	Auto release after 1 min		
		Release Once Discharge	Discharge Current > 1A		

	Release				
6	Over-current-1 Discharge Protection	Over-current-1 Discharge Alarm	205A	Can be set	After 10 times, the state will be locked and no longer automatically release
		Over-current-1 Discharge Protection	210A	Can be set	
		Over-current Protection Delay Time	1.0S	Can be set	
	Over-current-1 Discharge Protection Release	Auto Release	Auto release after 1 min		
	Release Once Charge		Charge Current > 1A		
7	Over-current-2 Discharge	Over-current-2 Discharge Protection	≥250A	Can be set	After 10 times, the state will be locked and no longer automatically release
		Over-current-2 Protection Delay Time	500mS	Can be set	
	Over-current-2 Protection Release	Auto Release	Auto release after 1 min		
		Release Once Charge	Charge Current > 1A		
8	Short Circuit Protection	Short Circuit Protection Function	exist		
		Short Circuit Current Protection Release	When there is charging, the short circuit protection is lifted		
			When the load is removed, it will be removed automatically		
9	MOS Over - Temperature Protection	MOS Over Temperature Alarm	90°C	Can be set	
		MOS Over Temperature Protection	110°C	Can be set	
		MOS Over Temperature Protection Release	85°C	Can be set	
10	Cell Temperature Protection	Under Temperature Charge Alarm	5°C	Can be set	
		Under Temperature Charge Protection	0°C	Can be set	
		Under Temperature Charge Protection Release	5°C	Can be set	
		Over Temperature Charge Alarm	60°C	Can be set	
		Over Temperature Charge Protection	65°C	Can be set	
		Over Temperature Charge Protection Release	55°C	Can be set	
		Under Temperature Discharge Alarm	-15°C	Can be set	
		Under Temperature Discharge Protection	-20°C	Can be set	
		Under Temperature Discharge Protection Release	-15°C	Can be set	
		Over Temperature Discharge Alarm	65°C	Can be set	
		Over Temperature Discharge Protection	70°C	Can be set	
		Over Temperature Discharge Protection Release	60°C	Can be set	

11	ENV Temperature Alarm	ENV Under Temperature Alarm	-15°C	Can be set	
		ENV Under Temperature Protection	-20°C	Can be set	
		ENV Under Temperature Protection Release	-15°C	Can be set	
		ENV Over Temperature Alarm	65°C	Can be set	
		ENV Over Temperature Protection	70°C	Can be set	
		ENV Over Temperature Protection Release	65°C	Can be set	
12	Consumption Current	Operation Mode	≤45mA (with LCD)		
			≤40mA (without LCD)		
		Low Power Mode	≤200μA		
13	Cell Balance	Balance Threshold	3400mV	Can be set	
		ΔVcell	30mV	Can be set	
14	Capacity default Settings	Low power alarm	SOC < 5%	Can be set	No alarm when charging
15	Sleep	sleep voltage	3150mV	Can be set	
		Delay time	5min	Can be set	
16	Cell failure protection	ΔVcell	Δcell > 1V	Do not set	Charging and discharging is not allowed
17	Filled judgment	Full charge pressure	> 56V	Can be set	At the same time, stop charging after meeting, and update the SOC to 100%
		Cut-off current	< 2A	Can be set	

LED Instructions :

State	Normal / Alarm / Protection	RUN	ALM	Instructions
				
Power Off	Sleep	OFF	OFF	All off
Standby	Normal	flash1	OFF	Standby
	Alarm	flash1	Flash3	Cell low voltage
Charge	Normal	ON	OFF	Maximum power LED flash(flash 3),ALM does not flash for overcharge warning
	Alarm	ON	Flash3	
	Over Charge Protection	ON	OFF	If no mains supply, LED as standby
	Temperature. Over-current Fault Protection	OFF	ON	Close charge
Discharge	Normal	Flash3	OFF	
	Alarm	Flash3	Flash3	
	Under Discharge Protection	OFF	OFF	Close discharge
	Temperature. Over-current. Short Circuit Fault Protection	OFF	ON	Close discharge
Fault		OFF	ON	Close charge Close discharge

BMS features

Highly integrated analog front end

Adjustable over-current protection

Isolated power supply circuit

Multiple sleep and wake-up methods

Integrated serial IC

Low power consumption

High voltage accuracy ($\leq 20\text{mV}$)

Dual RS485 communication

Parameter adjustable setting

4 way battery temperature detection ($\leq 2^\circ\text{C}$)

Buzzer alarm function

SOC estimation function

High current accuracy ($\leq 2\%@\text{FS}$)

SOH estimation function

With charge equalization function

Short circuit protection function

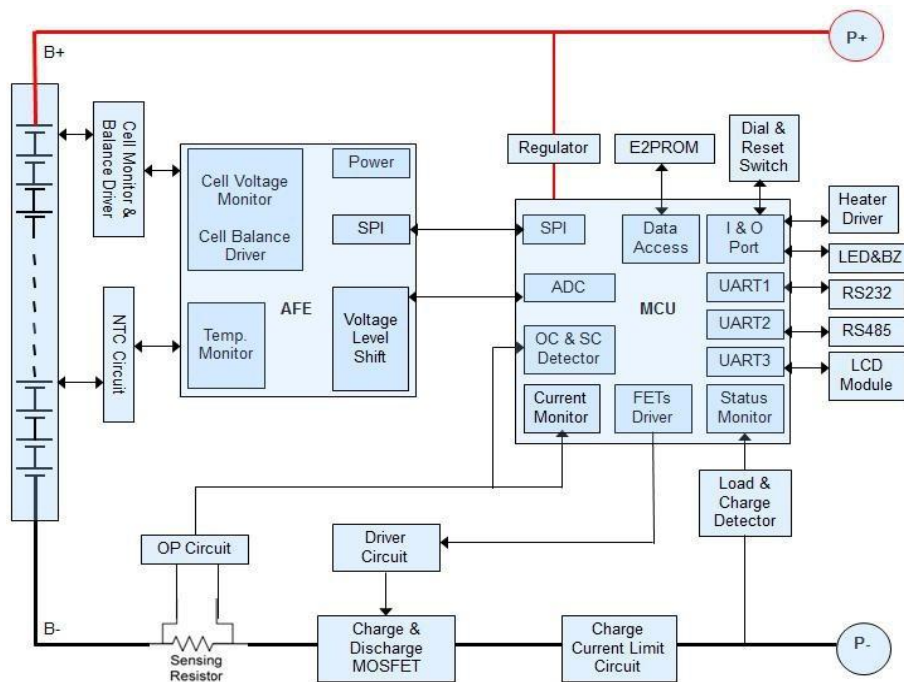

3. Safe handling of lithium batteries Guide

3.1 Schematic Diagram of Solution

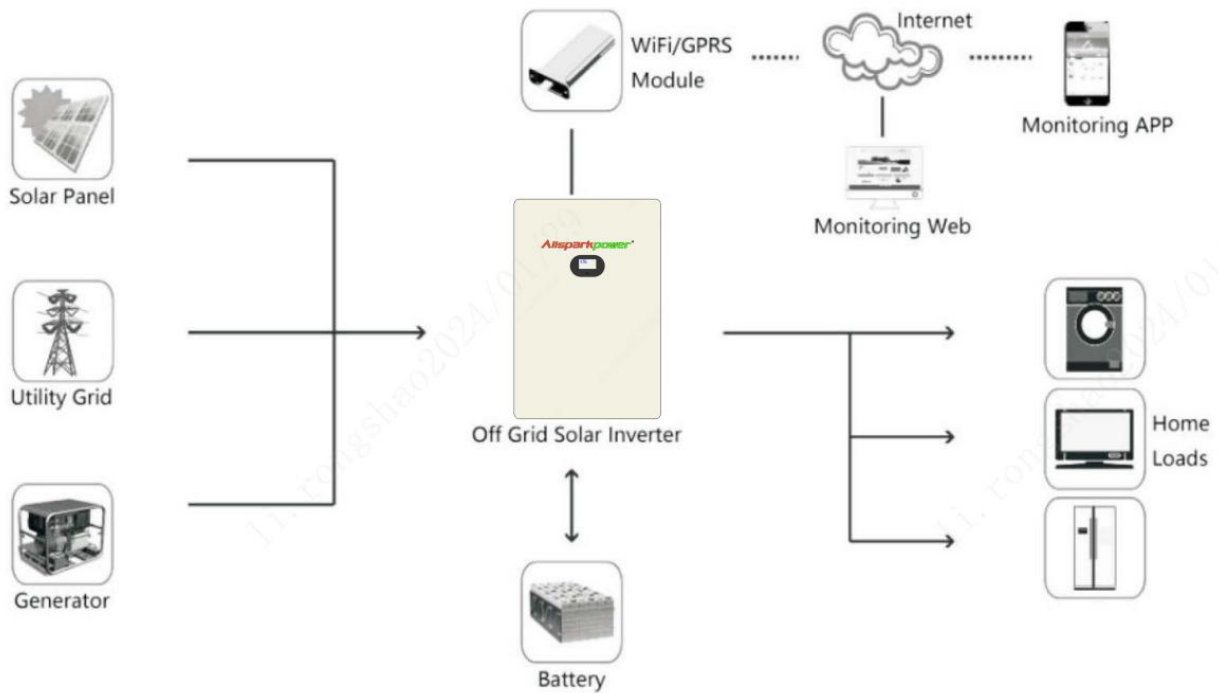

3.2 Explanation of Symbol

DANGER

DANGER LOW DC VOLTAGE INSIDE
DANGER ARC FLASH & SHOCK HAZARD

- * Do not cover or wrap the product case.
- * Do not place at a children or pet touchable area.
- * Do not disconnect or disassemble by non-professional personnel.
- * Do not drop, deform, impact, cut or spearing with a sharp object.
- * Do not sit or put heavy things on battery.
- * Do not touch the leaking liquid.
- * Do not place near open flame or flammable material.
- * Avoid of moisture or liquid.
- * Avoid of direct sunlight.
- * The product Ingress Protection (IP) class is IP54.
- * Make sure the grounding connection set correctly before operation.
- * Follow the product manual to make wiring connection.
- * If leaking, fire, wet or damaged, switch off the breaker on DC side and stay away from battery.
- * Contact your supplier within 24 hours if anything failure happens.

3.3 Tools

The following tools are required to install the battery pack.

		
<p>Wire cutter</p>	<p>Crimping Modular Plier</p>	<p>Electric drill</p>

NOTE

Use properly insulated tools to prevent accidental electric shock or short circuits.

If insulated tools are not available, cover the entire exposed metal surfaces of the available tools, except their tips, with electrical tape.

3.4 Safety Gear

It is recommended to wear the following safety gear when dealing with the battery pack.

		
<p>Insulated gloves</p>	<p>Safety goggles</p>	<p>Safety shoe</p>

4. Installation

4.1 Package Items

Unpacking and check the Packing List

For Battery system connects to inverter: Each energy storage system has 2 communication cable, 1 grounding wire, and 2 power wires

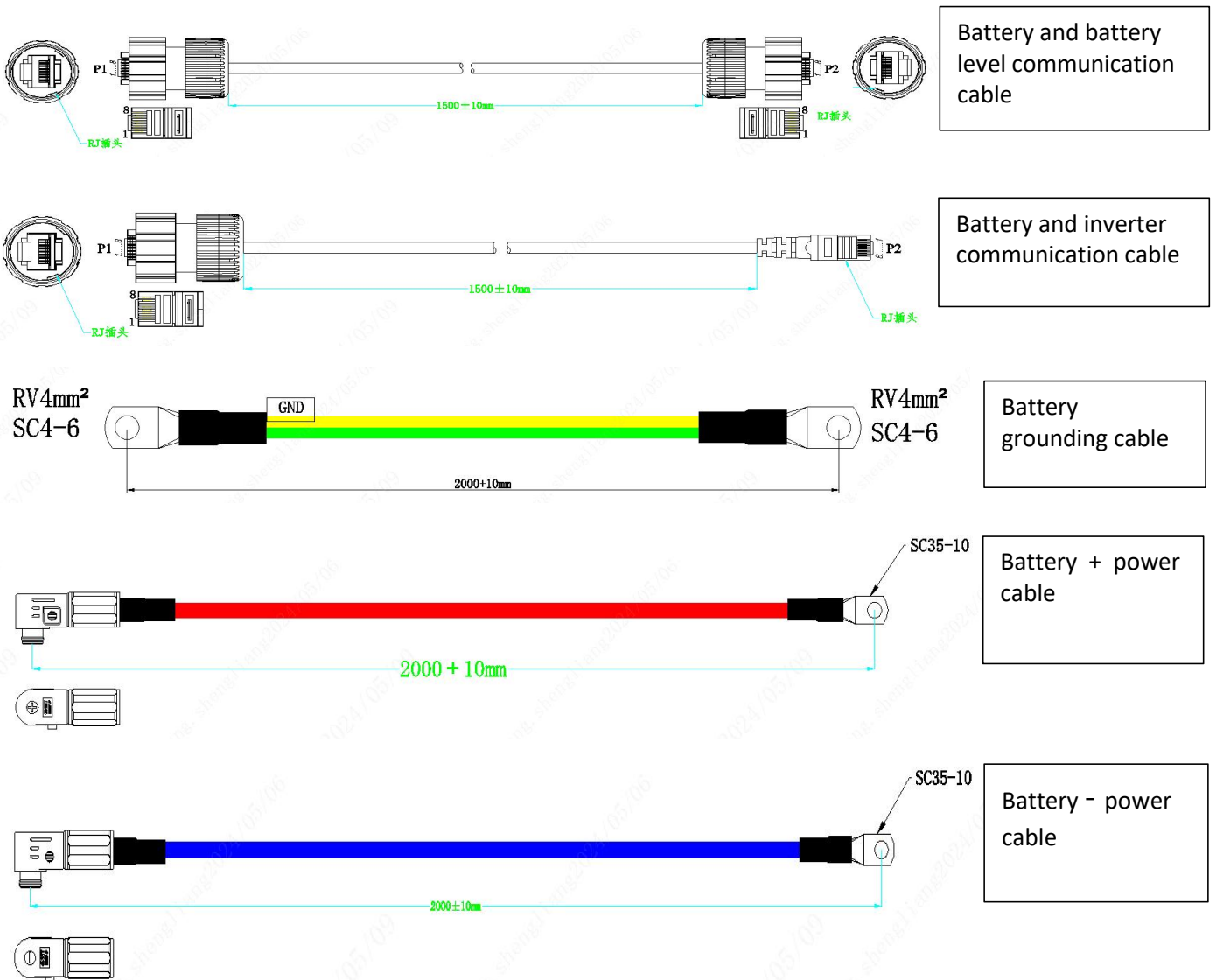

Install the grounding cable to the module's grounding point before use.

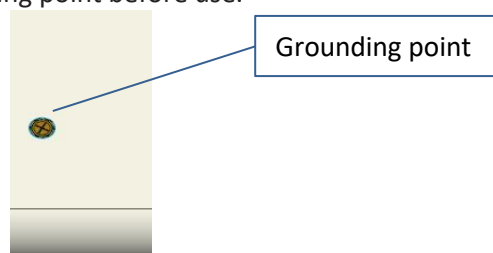

INSTALL

Install: First, install and fix the installation bracket to the wall with expansion screw.
Then hang the battery on the bracket.

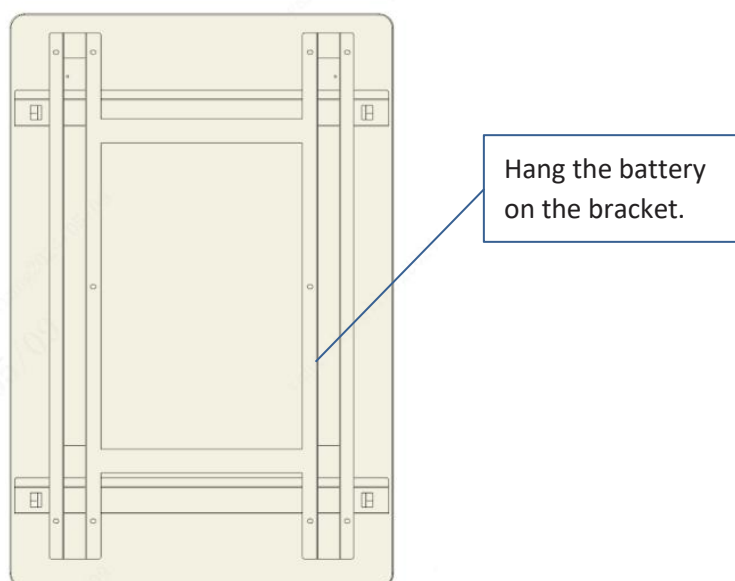
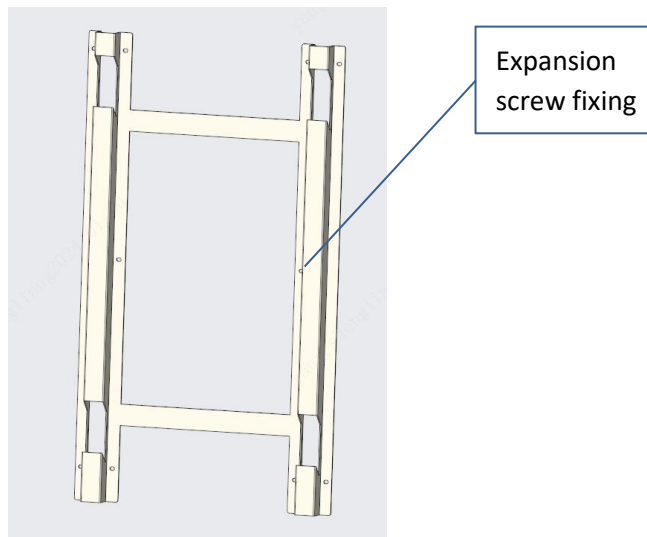
**NOTE**

These cables are accessories and are not included in the battery pack. They are in another accessory box. If there are any omissions, please contact the dealer.

4.2 Installation Location

- ✧ Make sure that the installation location meets the following conditions: The area is completely water proof.
- ✧ The floor is flat and level.
- ✧ There are no flammable or explosive materials.
- ✧ The ambient temperature is within the range from 0°C to 50°C. The temperature and humidity is maintained at a constant level. There is minimal dust and dirt in the area.
- ✧ The distance from heat source is more than 2 meters.
- ✧ The distance from air outlet of inverter is more than 0.5 meters. Do not cover or wrap the battery case or cabinet.
- ✧ Do not place at a children or pet touchable area. The installation area shall avoid of direct sunlight.
- ✧ There is no mandatory ventilation requirements for battery module, but please avoid of installation in confined area. The aeration shall avoid of high salinity, humidity or temperature.



CAUTION

If the ambient temperature is outside the operating range, the battery pack stops operating to protect itself. The optimal temperature range for the battery pack to operate is 0°C to 50°C. Frequent exposure to harsh temperatures may deteriorate the performance and life of the battery pack.

5. Trouble Shooting Steps

5.1 Problem determination based on:

- 1) Whether the battery can be turned on or not;
- 2) If battery is turned on, check the alarm information on the display screen;
- 3) If the red light is off, check whether the battery can be charged / discharged or not.

5.2 Preliminary determination steps:

- 1) Battery can not turn on, the display screen can not light up normally.

If the battery external switch is ON, the display screen lights up normally, and the external power supply voltage is 48V or more, the battery still unable to turn on, please contact distributor.

- 2) The battery can be turned on, but display screen display malfunction, and can not charge or discharge. If display screen display malfunction, that means system is abnormal, please check values as following:

- a) Temperature: Above 50 °C or under -10°C, the battery could not work.

Solution: to move battery to the normal operating temperature range between -10 °C and 50°C.

- b) Current: If current is greater than 200A, battery protection will turn on.

Solution: Check whether current is too large or not, if it is, to change the settings on power supply side.

- c) High Voltage: If charging voltage above 58.4V, battery protection will turn on.

Solution: Check whether voltage is too high or not, if it is, to change the settings on power supply side.

- d) Low Voltage: When the battery discharges to 44.8V or less, battery protection will turn on. Solution:

Charge the battery for some time, the fault information elimination.

Excluding the four points above, if the faulty is still cannot be located, turn off battery and repair.

5.3 The battery cannot be charged or discharged

- 1) Cannot be charged:

Disconnect the power cables, measure voltage on power side, if the voltage is 54~58.4V, restart the battery, connect the power cable and try again, if still not work, turn off battery and contact distributor .

- 2) Unable to discharge:

Disconnect the power cables and measure voltage on battery side, if it is under 44.8V, please charge the battery; if voltage is above 51.2V and still cannot discharge, turn off battery and contact distributor

6. Emergency Situations

6.1 Leaking Batteries

If the battery pack leaks electrolyte, avoid contact with the leaking liquid or gas. If one is exposed to the leaked substance, immediately perform the actions described below.

Inhalation: Evacuate the contaminated area, and seek medical attention.

Contact with eyes: Rinse eyes with flowing water for 15 minutes, and seek medical attention. Contact with skin:

Wash the affected area thoroughly with soap and water, and seek medical attention.

Ingestion: Induce vomiting, and seek medical attention.

6.2 Fire

NO WATER! Only dry powder fire extinguisher can be used; if possible, move the battery pack to a safe area before it catches fire.

6.3 Wet Batteries

If the battery pack is wet or submerged in water, do not let people access it, and then contact us or an authorized dealer for technical support.

6.4 Damaged Batteries

Damaged batteries are dangerous and must be handled with the utmost care. They are not fit for use and may pose a danger to people or property. If the battery pack seems to be damaged, pack it in its original container, and then return it to us or an authorized dealer.

NOTE:

Damaged batteries may leak electrolyte or produce flammable gas.

In case a damaged battery needs recycling, it shall follow the local recycling regulation (ie. Regulation (EC) Nº 1013/2006 among European Union) to process, and using the best available techniques to achieve a relevant recycling efficiency.

Allsparkpower[®]

Hunan Allsparkpower Storage Technology Co.,Ltd.

Office Add: 3rd Floor, Building C5, Golden Innovation Park, Changsha, China.

Tel: 0086-0731-85368837

Email: info@allsparkpower.cn

Web: www.allsparkpower.cn